

Upper #10031
Lower #10017

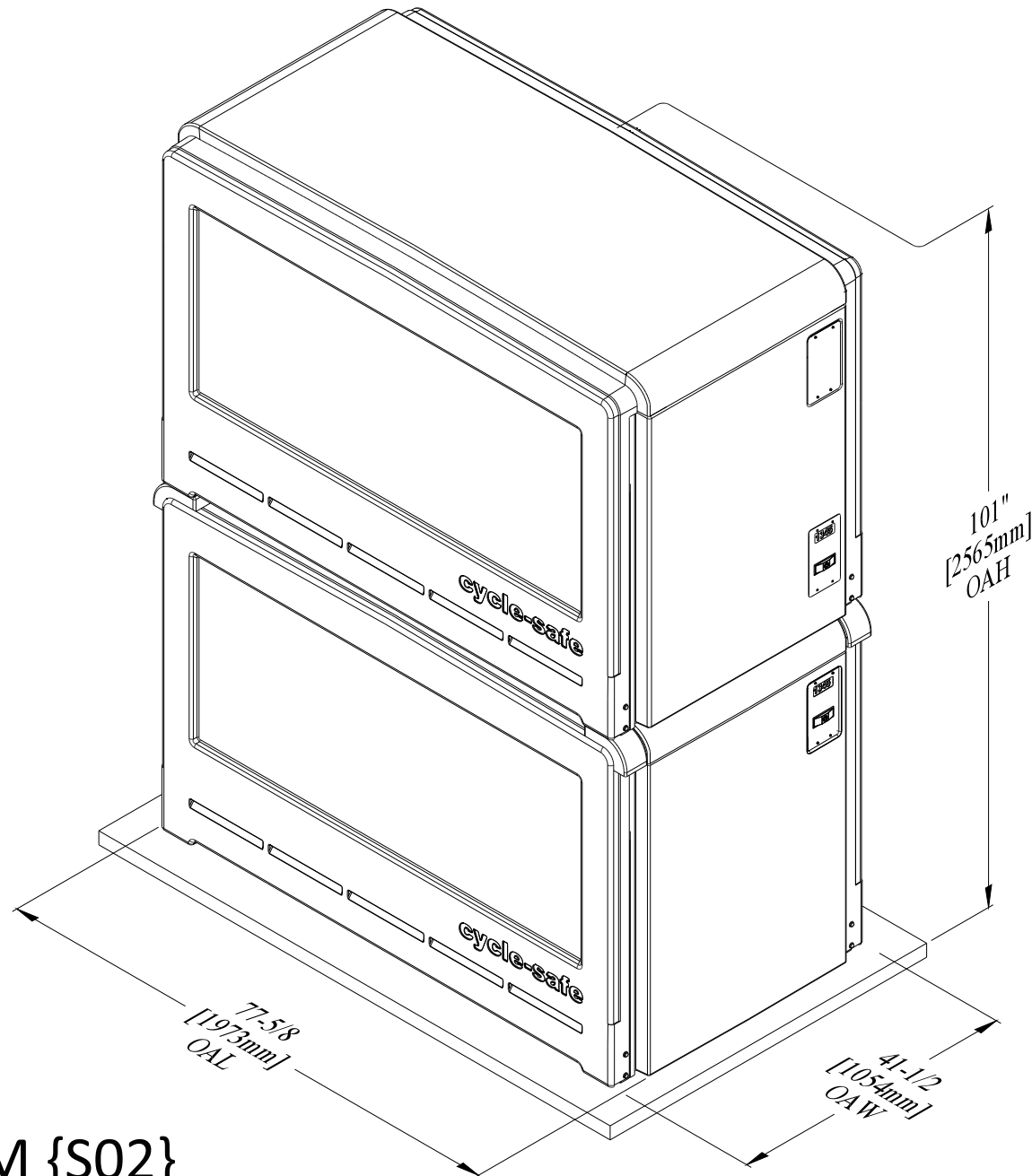

ProPark DT/SM {S02}
{2-Tier} Standard Locker {Dims}



www.cyclesafe.com

Upper's 10031 & 10051
Lower's 10017 & 10019

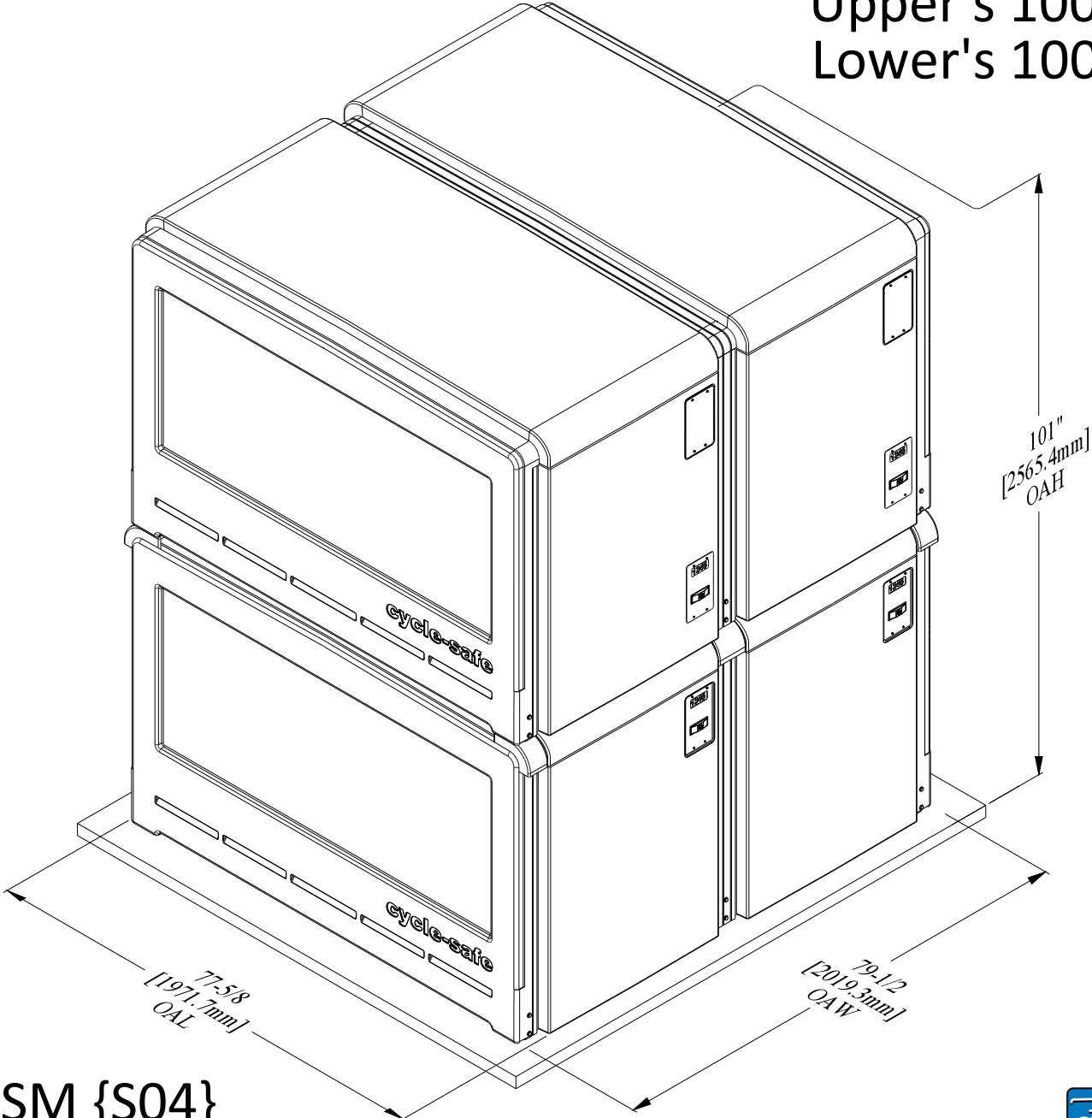

ProPark DT/SM {S04}
{2-Tier} Standard Locker {Dims}



www.cyclesafe.com

Upper #10002
Lower #10001

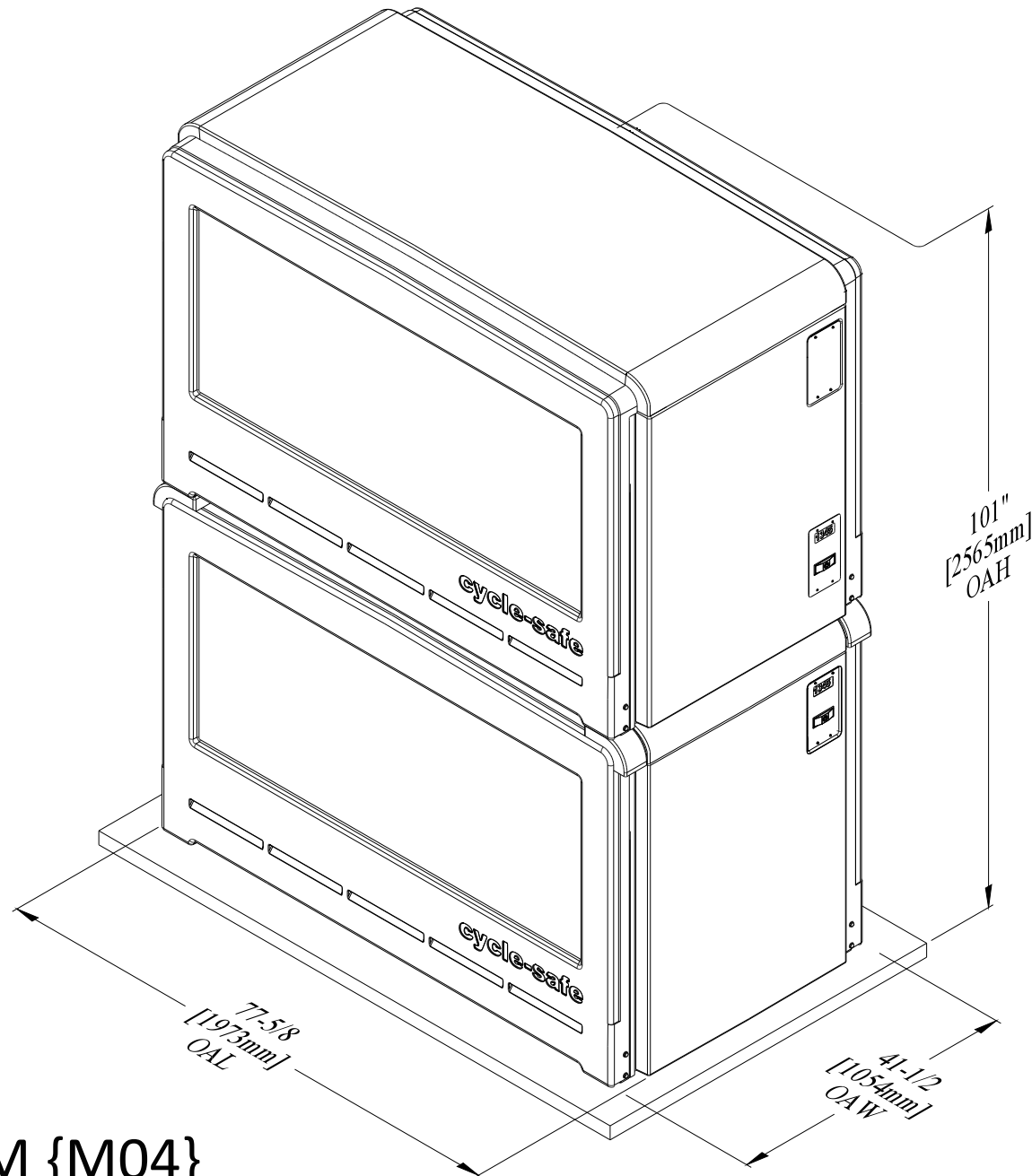

ProPark DT/SM {M04}
{2-Tier} Standard Locker {Dims}

Upper's 10002 & 10051
Lower's 10001 & 12500

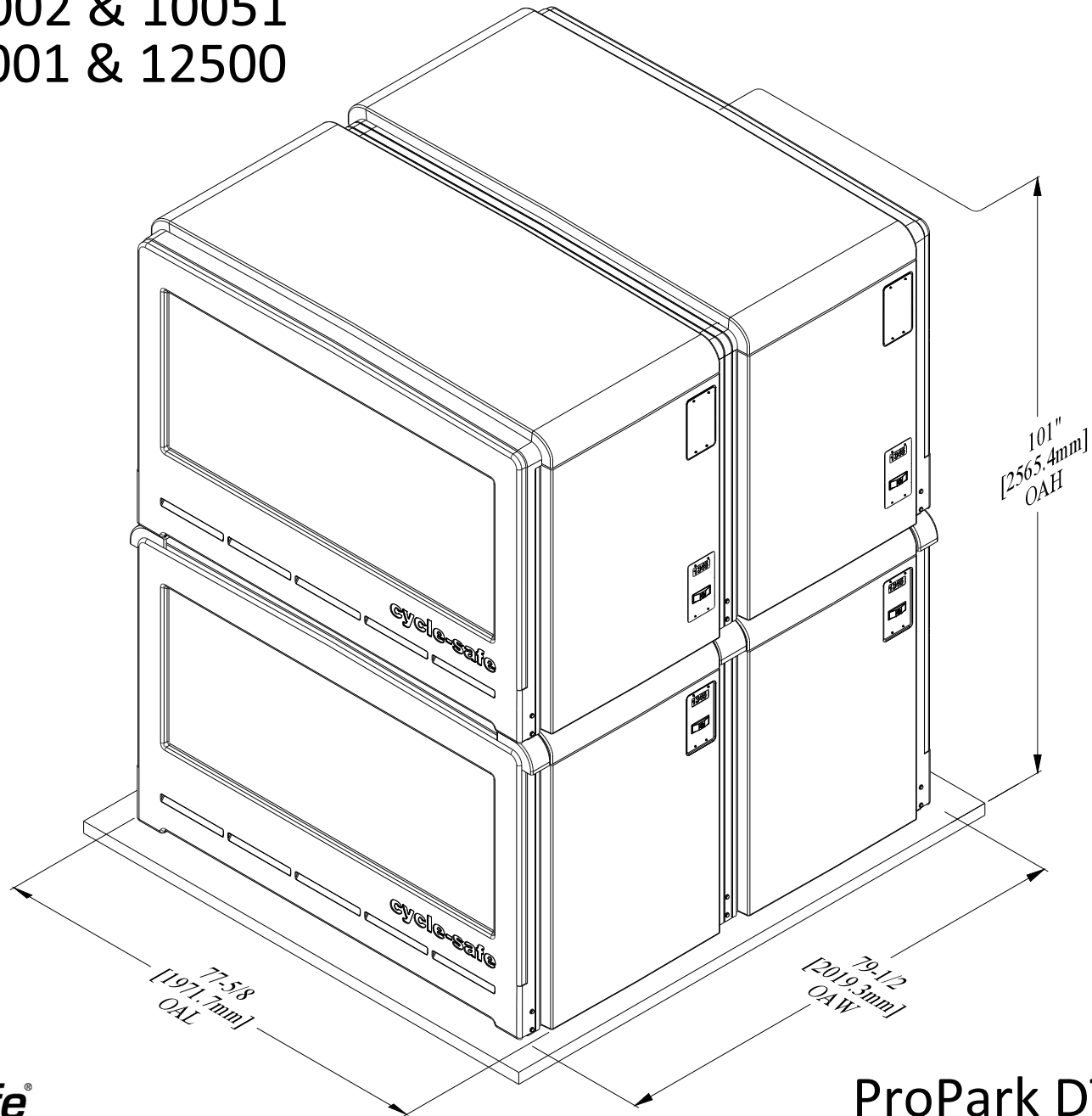

NOTE:

INCLINE ANGLES

A. DOOR-TO-DOOR INCLINE TO BE NO MORE THAN 1 ° SLANT

B. BANKING SIDE-TO-SIDE TO BE NO MORE THAN 2 ° SLANT

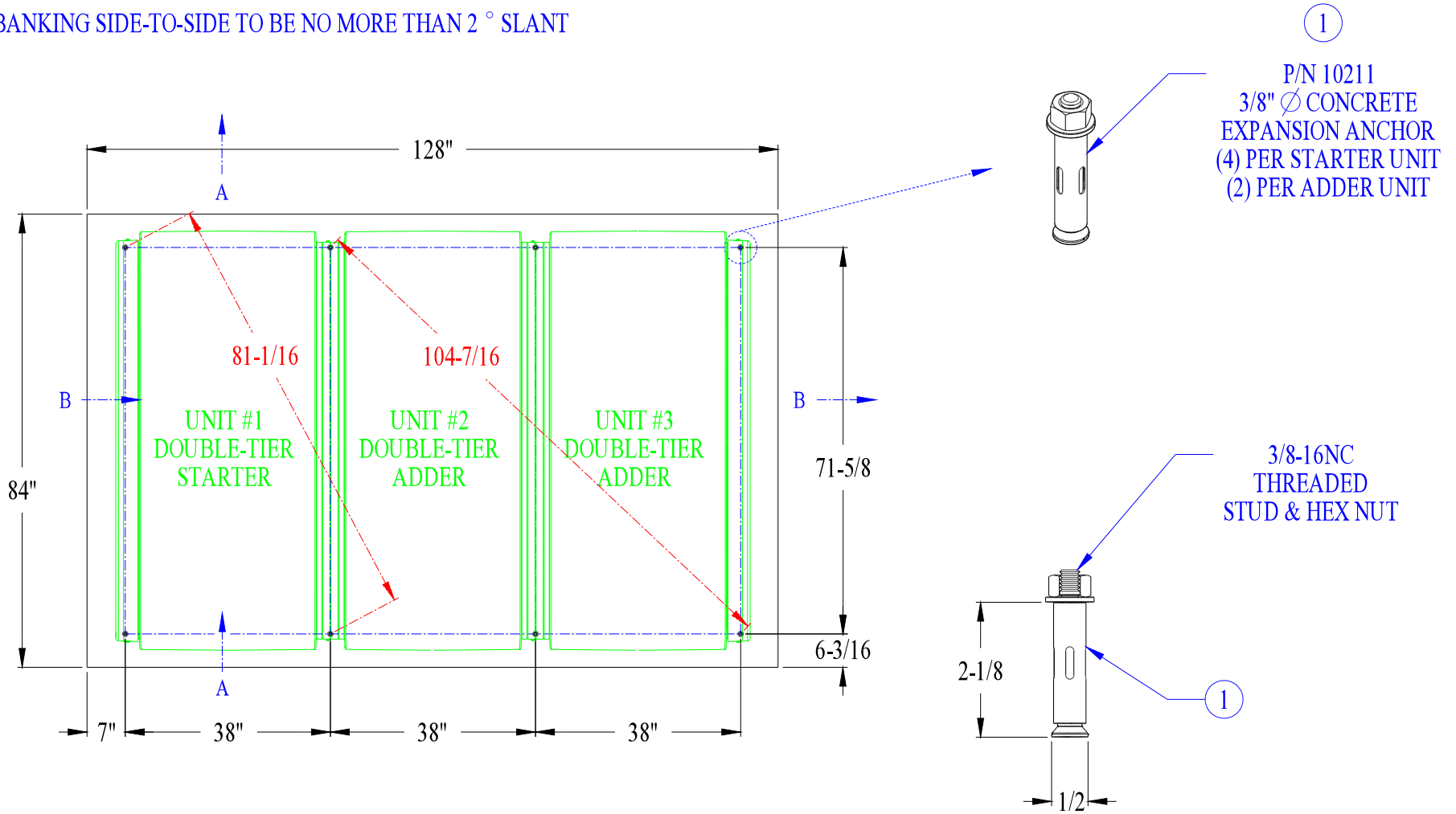

ProPark DT {M12} Lockers Anchor Placement Locations

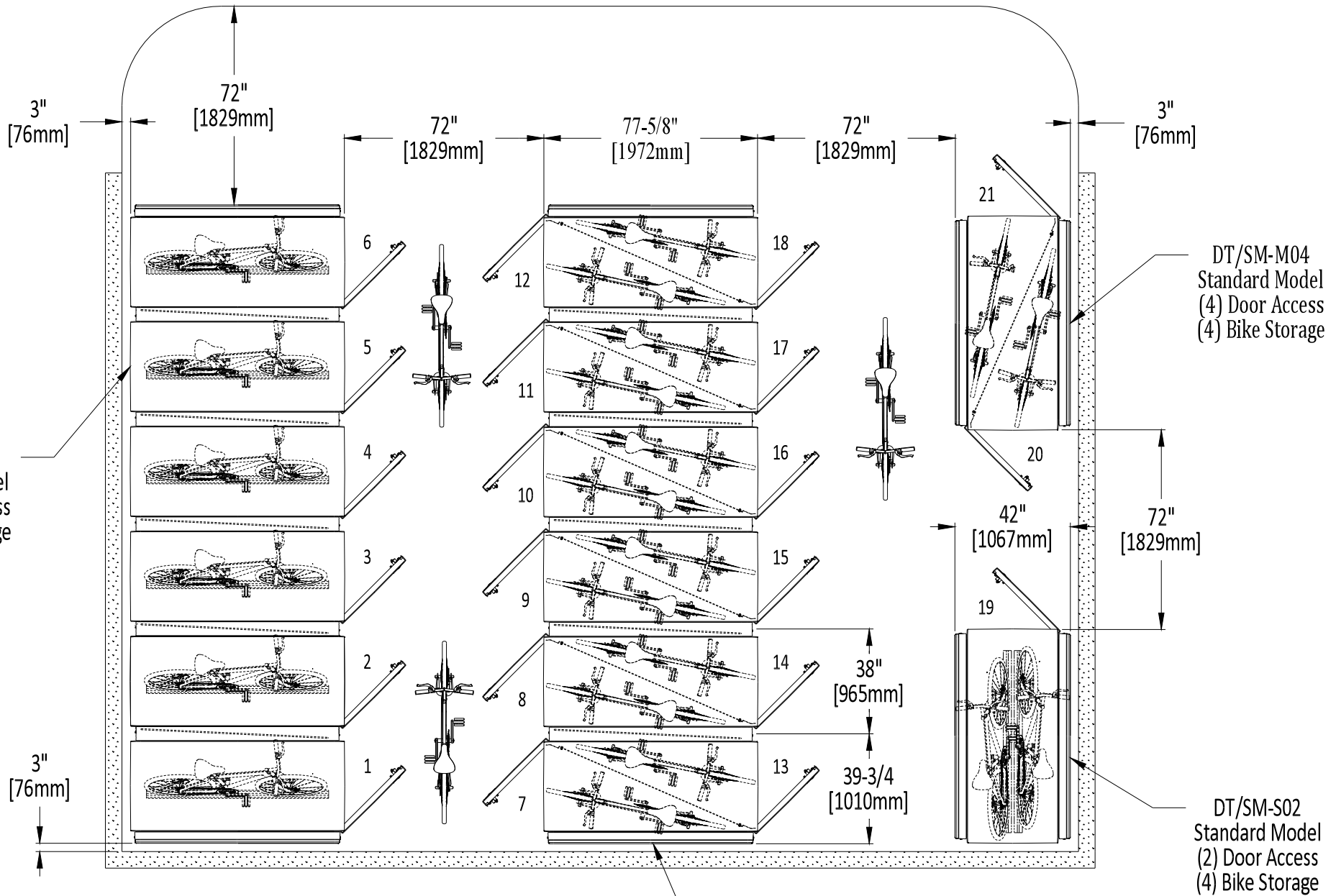

CycleSafe {ProPark} Double-Tier Locker Clearance & Capacities